

INCLUDED:
 SUPPLY WIRE HARNESS
 PARTS N°: PEH 0962 142 100
 (142) = wire type
 (100) = length in cm

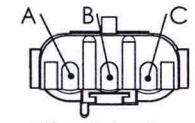

Wire side view
 Connector : Delphi Nr. 12010717
 Terminals : Delphi Nr. 12089040
 Wire seal : Delphi Nr. 15324985

PIN N°	FUNCTION	COLOR
A	Analog Ground 0V	WHITE
B	Analog Signal 0,5 - 4,5V	BLACK
C	Analog Supply +5V	RED

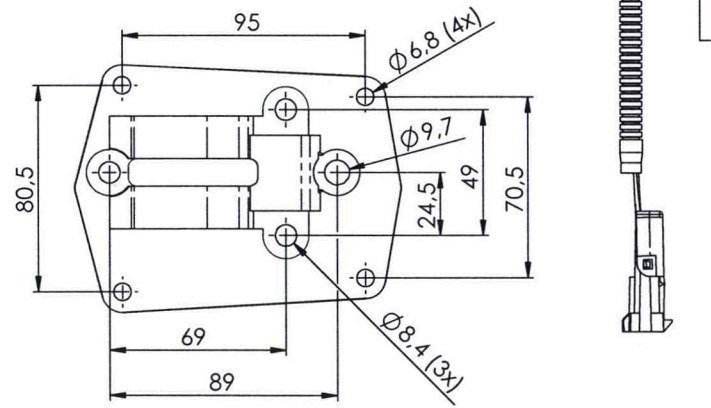
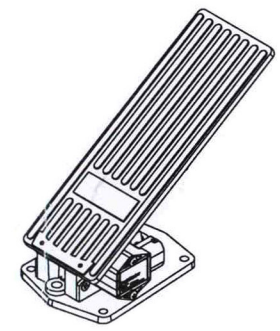

!!! WARNING !!!
 Connect throttle sensor ground
 to engine ECU ground terminals only.
 DO NOT CONNECT TO CHASSIS GROUND

UNLESS OTHERWISE SPECIFIED: DIMENSIONS ARE IN MILLIMETERS TOLERANCES: LINEAR: +/- 1mm ANGULAR: +/- 1°		FINISH:	PROJECTION:	DO NOT SCALE DRAWING	SIZE: A3
DRAWN		NAME	CREATED DATE	PART NR: 962 130 L113	
CHK'D		SB	6/04/2021	TITLE: Throttle Pedal 30° Single analogue 0.5-4.5V with wire harness	
MATERIAL:		MCS MOBILE CONTROL SYSTEMS SA		DWG NO. 506 716	REV: -
This drawing is confidential and remains the sole property of Mobile Control Systems S.A. This document is protected in accordance with the prevailing law.		WEIGHT: - gr		SCALE:1:2	SHEET 1 OF 1